

AASHTOWare BrDR 7.5.0

Distribution Factor-Line Girder Analysis Tutorial

DF3 – Distribution Factor Analysis (NSG-LRFR) Example

DF3 - Distribution Factor Analysis (NSG - LRFR)

Topics Covered

- Review Distribution Factor Analysis
 - Distribution Factor Analysis Method of Solution
 - Non-standard gage vehicle description
 - Vehicle paths
- BrDR Distribution Factor Engine Properties
- Perform Distribution Factor Analysis (NSG – LRFR)

Review Distribution Factor Analysis

This example describes the distribution factor analysis feature in BrDR to determine the adequacy of a superstructure for a standard gage or non-standard gage vehicle.

Distribution Factor Analysis Method of Solution

The Distribution Factor Analysis feature computes live load distribution factors for a vehicle traveling in a specified path along the length of the superstructure. This feature allows you to analyze a bridge for standard gage or non-standard gage vehicles.

A 3D and 2D finite element analysis of the superstructure is performed, moment and shear live load distribution factors are computed for a vehicle traveling along user-specified paths along the length of the superstructure. The computed distribution factors are then used to perform a rating analysis using traditional line girder analysis techniques.

In the 3D finite element model, the deck is modeled as shell elements and the girders are modeled as beam elements. The deck is always included in the model regardless of whether the girders are composite with deck. Diaphragms are not included in the 3D finite element model.

BrDR determines which nodes in the 3D FE model should be loaded with the vehicle by using the vehicle path location and vehicle wheel description entered by the user. Unit loads are placed at each of these nodes in the 3D FE model and the resulting moment and shear element forces in the beam elements are stored. Moment and shear influence surfaces are generated from these element forces. The influence surfaces are then loaded with the vehicle traveling along the user-defined vehicle path. The moments and shears in the girders due to the actual distribution of the vehicle through the deck are then computed.

A 2D finite element analysis is then performed for each girder. The 2D FE model consists of the girder modeled as beam elements. The nodes in the 2D FE model are at the same locations as the nodes in the 3D FE model.

DF3 - Distribution Factor Analysis (NSG - LRFR)

Unit loads are placed at each node along the girder in the 2D FE model and the moment and shear influence lines are generated for the girder. These influence lines are then loaded with the axle weights of the vehicle traveling along the superstructure and the resulting moments and shears in the girder are then computed.

Moment and shear distribution factors are computed by dividing the 3D model moments and shears by the 2D model moments and shears. These distribution factors are the ratio of the 3D actions to the 2D actions. The critical moment distribution factor is chosen for each vehicle path by first finding the moment distribution factors that correspond to the maximum 2D moment and the minimum 2D moment. The critical moment distribution factor is the maximum of these 2 moment distribution factors. The critical shear distribution factor is determined in the same manner. A traditional line girder analysis of the girder is then performed using these critical distribution factors.

Non-standard gage vehicle description

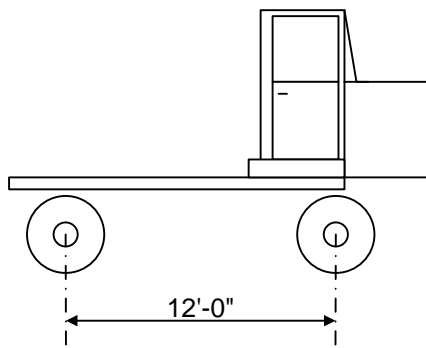

Elevation View

NSG Truck Load Data		
Front Axle	Load/Axle Line	40 kips
	Load/Tire	20 kips
Rear Axle	Load/Axle Line	48 kips
	Load/Tire	12 kips
Total Vehicle Weight		88 kips

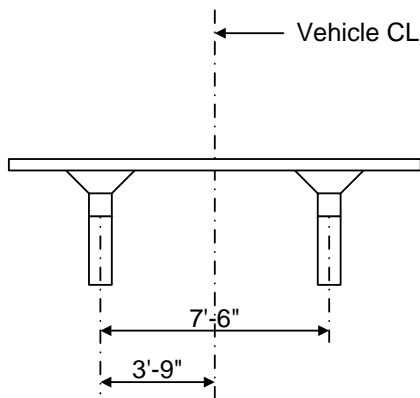

End View of Front Axle

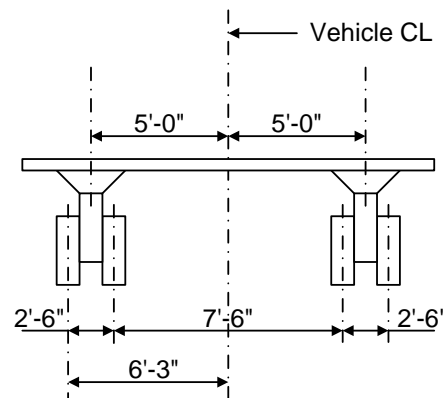

End View of Rear Axle

DF3 - Distribution Factor Analysis (NSG - LRFR)

The preceding non-standard gage vehicle can be entered in the BrDR vehicle library as follows. Open the **Library Explorer** and select **Non-Standard Gage** in the Library tree. Select **New** from the **Manage** Group to open the **Vehicle: Non-Standard Gage: New Item** window.

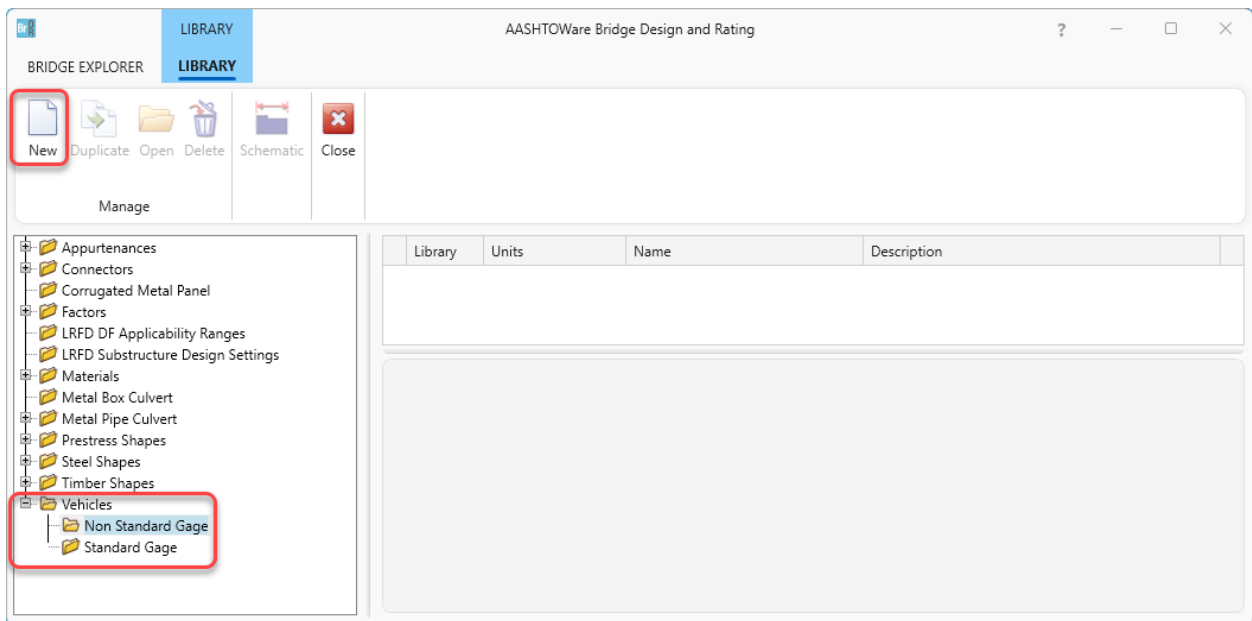
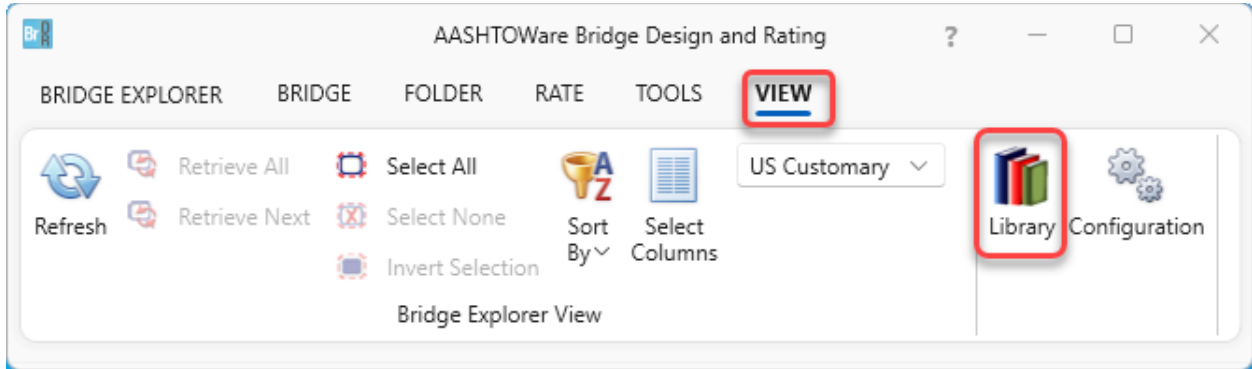

DF3 - Distribution Factor Analysis (NSG - LRFR)

The description for the first axle of the vehicle is shown below.

Vehicle: Non-Standard Gauge: New Item

Name:

Description:

Store units as: US SI

Library: Standard Agency defined User defined

Description

Axes

Axle	Distance to first wheel (ft)	Axle spacing (ft)	Total axle load (kip)
1	-3.75		40
> 2	-6.25	12	0

Totals: 12.00 40.00

Wheels

Axle: 1

Wheel	Wheel spacing (ft)	Wheel contact width (in)	Wheel load (kip)
> 1		16	20
2	7.5	16	20

Total (for axle): 40.00

Rating

ASR/LFR

LRFR

To be able to select this vehicle in the Analysis Settings window when doing a rating, be sure to check the rating boxes.

When describing the axles, the **Distance to first wheel** is the distance from the centerline of the vehicle to the first wheel in the axle. This value is a negative value to signify the first wheel is to the left of the vehicle centerline. The following sketch illustrates the terminology used in this window.

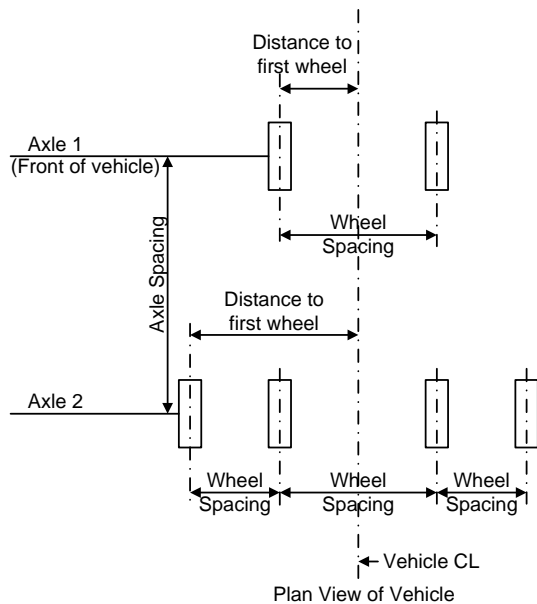

DF3 - Distribution Factor Analysis (NSG - LRFR)

The description of the wheels in the second axle of the vehicle is shown below.

Vehicle: Non-Standard Gage: New Item

Name: NSG Truck

Description:

Store units as: US SI

Library: Standard Agency defined User defined

Description

Axes

Axle	Distance to first wheel (ft)	Axle spacing (ft)	Total axle load (kip)
1	-3.75		40
> 2	-6.25	12	48

Totals: 12.00 88.00

New Duplicate Delete

Wheels

Axle: 2

Wheel	Wheel spacing (ft)	Wheel contact width (in)	Wheel load (kip)
> 1		16	12
2	2.5	16	12
3	7.5	16	12
4	2.5	16	12

Total (for axle): 48.00

New Duplicate Delete

Rating: ASR/LFR LRFR

Save Close

Click **Save** to save this vehicle to the library.

DF3 - Distribution Factor Analysis (NSG - LRFR)

A **schematic** view of the vehicle and each axle is available to verify your data entry by selecting the **NSG Truck** and clicking the **Schematic** button as shown below.

The screenshot shows the AASHTOWare Bridge Design and Rating software interface. The 'BRIDGE EXPLORER' sidebar on the left has the 'LIBRARY' tab selected. The 'Manage' toolbar contains buttons for 'New', 'Duplicate', 'Open', 'Delete', 'Schematic', and 'Close'. The 'Schematic' button is highlighted with a red box. The main window displays a table with columns 'Library', 'Units', 'Name', and 'Description'. The row for 'Agency Defined', 'US Customary', and 'NSG Truck' is highlighted with a red box. Below this, the 'Vehicle: Non-Standard Gage: NSG Truck' window is open, showing the 'Name' field set to 'NSG Truck' and the 'Store units as' radio buttons set to 'US'. The 'Library' section has 'Agency defined' selected. The 'Rating' section has 'ASR/LFR' and 'LRFR' checked. The 'Axles' table shows two axles with a total axle load of 48 kip for axle 2. The 'Wheels' table shows four wheels with a total load of 48.00 kip for axle 2.

Library	Units	Name	Description
Agency Defined	US Customary	NSG Truck	

Vehicle: Non-Standard Gage: NSG Truck

Name: NSG Truck

Store units as: US SI

Library: Standard Agency defined User defined

Rating: ASR/LFR LRFR

Axle	Distance to first wheel (ft)	Axle spacing (ft)	Total axle load (kip)
1	-3.75		40
2	-6.25	12	48

Totals: 12.00 88.00

Wheel	Wheel spacing (ft)	Wheel contact width (in)	Wheel load (kip)
1		16	12
2	2.5	16	12
3	7.5	16	12
4	2.5	16	12

Total (for axle): 48.00

DF3 - Distribution Factor Analysis (NSG - LRFR)

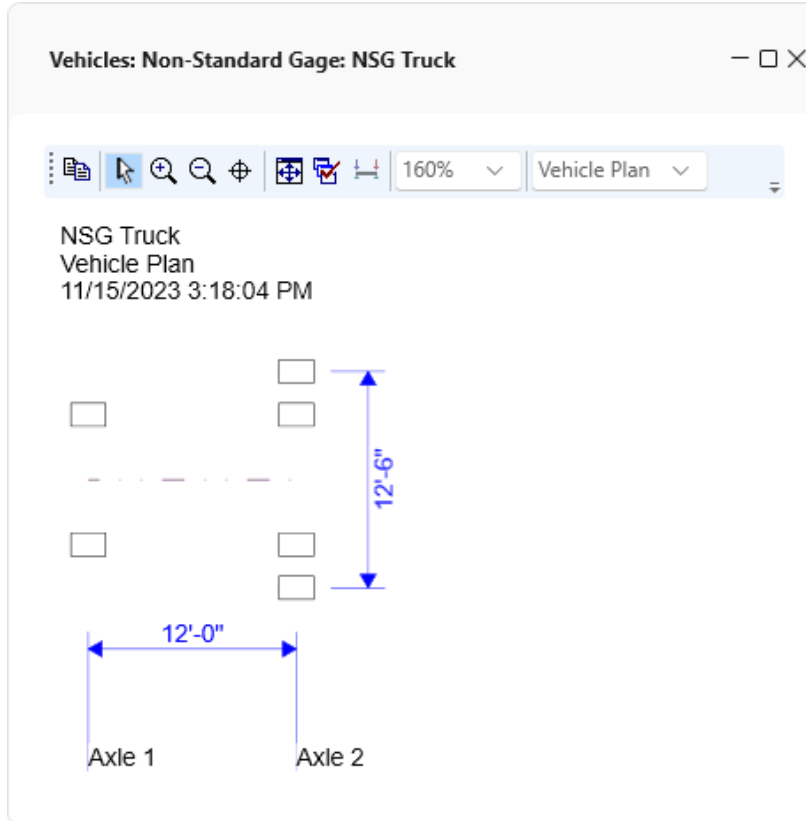

DF3 - Distribution Factor Analysis (NSG - LRFR)

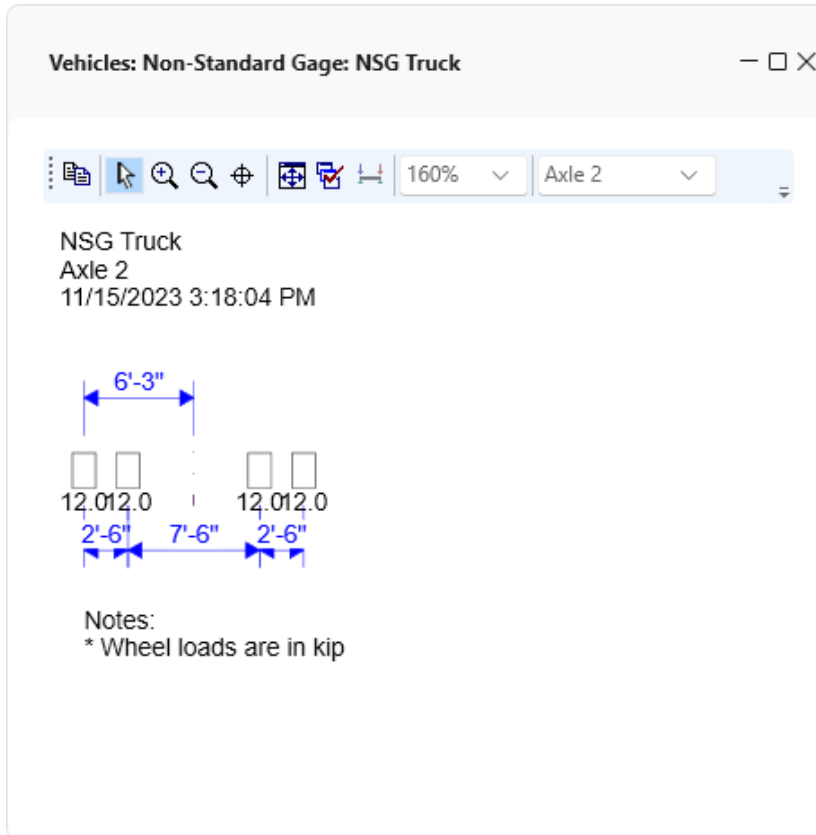

Vehicle paths

The distribution factor analysis is performed at the **SUPERSTRUCTURES** level. When performing a distribution factor analysis on a superstructure the analysis will be performed on the superstructure definition that is assigned to the existing **SUPERSTRUCTURE ALTERNATIVE**. This is necessary since in BrDR a bridge may consist of many superstructure definitions assigned to different locations along the length of the bridge.

DF3 - Distribution Factor Analysis (NSG - LRFR)

In this tutorial, **BID1 (TrainingBridge1)** in the **BrDR sample database** will be analyzed. Open the **Bridge Workspace** for **BID1**. The partially expanded **Bridge Workspace** for **BID1** is shown below. The distribution factor analysis for **Single Span Structure** will perform a 3D and 2D analyses of the **Simple Span Structure** which is assigned to the existing superstructure alternative.

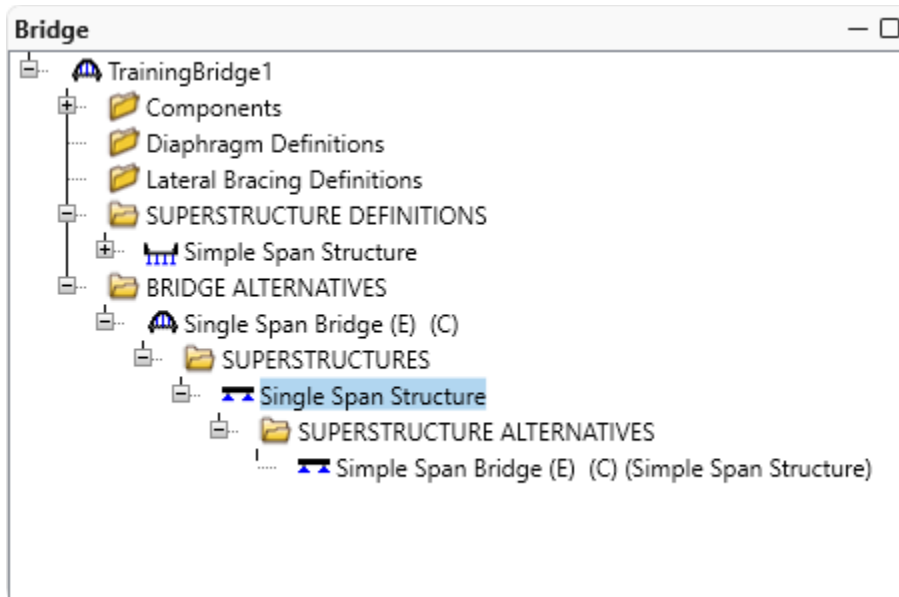

Double click on the **Single Span Structure** superstructure window and select the **Vehicle Path** tab.

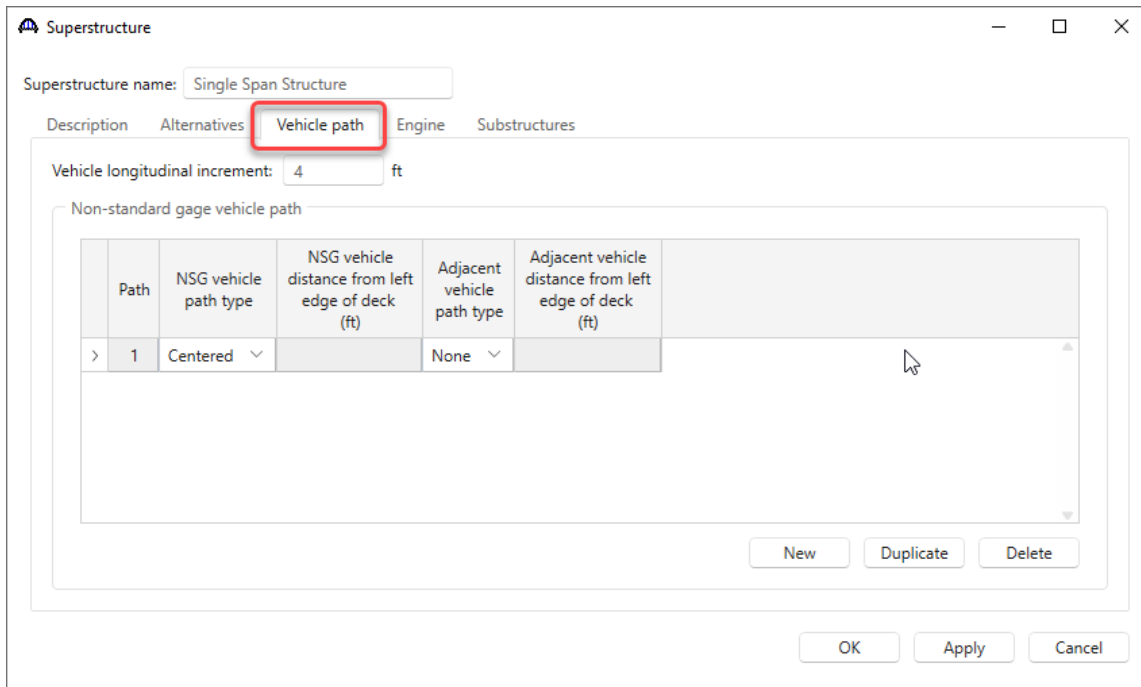

DF3 - Distribution Factor Analysis (NSG - LRFR)

This tab controls the placement of the vehicle that will be used in the distribution factor analysis. The **Vehicle longitudinal increment** is the longitudinal length increment to use when moving the vehicle along the length of the superstructure. Note that this value can greatly affect the time required for the analysis.

The vehicle path specifies the transverse location of the non-standard gage vehicle and an adjacent vehicle to use in the analysis. The following illustrates where the vehicles would be placed if the **NSG vehicle path** is specified as **Left** and the **Adjacent vehicle path** is specified as **Right**.

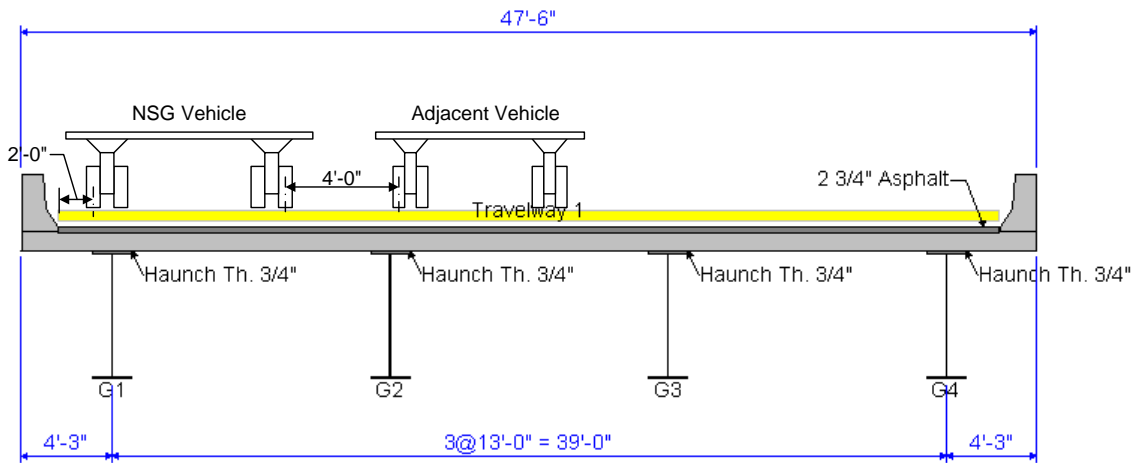

This example uses the **NSG vehicle path** specified as **Centered** and the **Adjacent vehicle path** as **None**. This path is shown below.

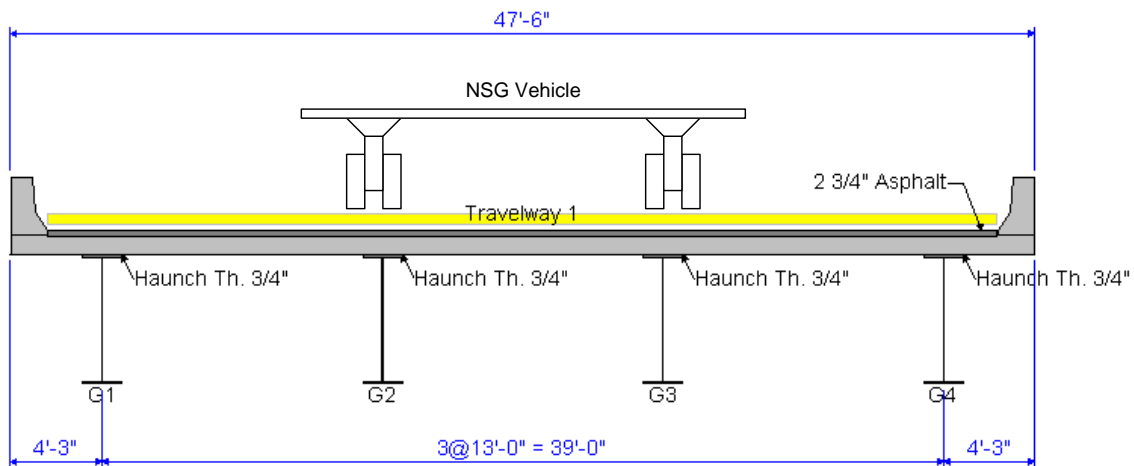

DF3 - Distribution Factor Analysis (NSG - LRFR)

BrDR Distribution Factor Engine Properties

Select the **Engine** tab in the Single Span Structure superstructure window. The Engine tab allows to specify properties for the analysis engine. Select **BrR Dist Fact Structure Prop** as the analysis module and then click **Properties** button.

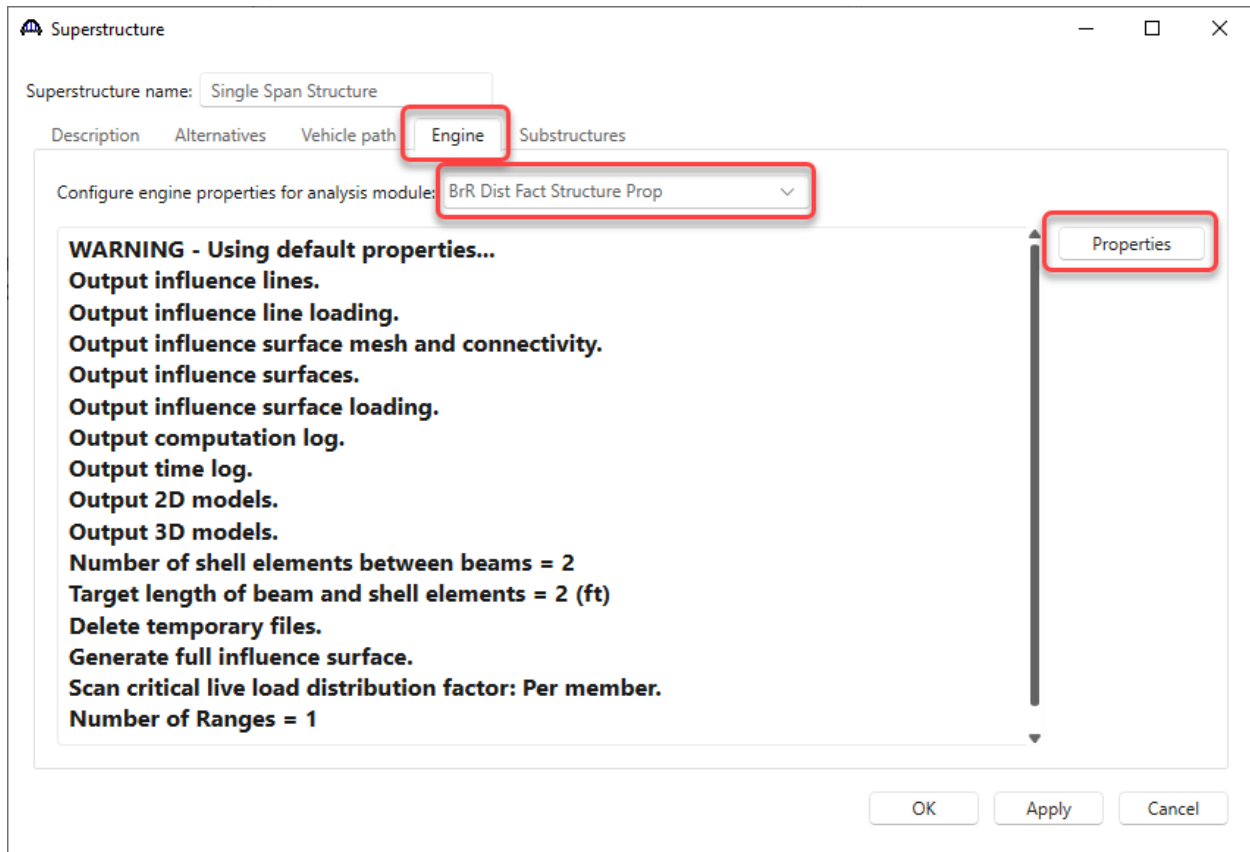

DF3 - Distribution Factor Analysis (NSG - LRFR)

The **Properties** button will bring up the below window

The screenshot shows the 'Analysis' window with the following settings:

- Output Control:** All options are checked: Influence lines, Influence line loading, Influence surface mesh and connectivity, Influence surfaces, Influence surface loading, Computation log, Time log, 2D models, and 3D models.
- Influence Surface Control:** 'Generate path influence surface' is selected. 'Delete temporary files' is also checked.
- Distribution Factor Engine Option:** 'Scan critical live load distribution factor' is set to 'Per member'. 'Number of ranges' is set to 1.
- Sliders:** 'Number of shell elements between beams' is set to 2. 'Target length of beam and shell elements' is set to 2 ft.

This window allows to specify the level of output needed from the analysis and allows to control how the FE models are created and loaded. The **Number of shell elements between beams** and **Target length of beam and shell elements** selections control the size of the elements in the model and greatly influence the time required for the analysis.

Select **Generate path influence surface** under **Influence Surface Control**. The **Scan critical live load distribution factor** selection allows to specify the method for determining the critical distribution factors. The **Per member** option specifies one critical moment and one critical shear distribution factors to be used for the whole member. The **One range per span** option specifies each span in the member has its own critical moment and shear distribution factors. The **Multiple ranges per span** option specifies each range in a span has its own critical moment and shear distribution factors. The length of the range is the span length divided by the entered **Number of Ranges**.

Click **OK** to close the **BrR Dist Fact Superstructure Properties** window and then click **OK** again to close the **Superstructure** window.

DF3 - Distribution Factor Analysis (NSG - LRFR)

Perform Distribution Factor Analysis (NSG – LRFR)

The distribution factor analysis can be initiated by selecting the **Single Span Structure** superstructure in the **Bridge Workspace** tree and clicking the **Analysis Settings** button in the **Analysis** Group of the **DESIGN/RATE** ribbon.

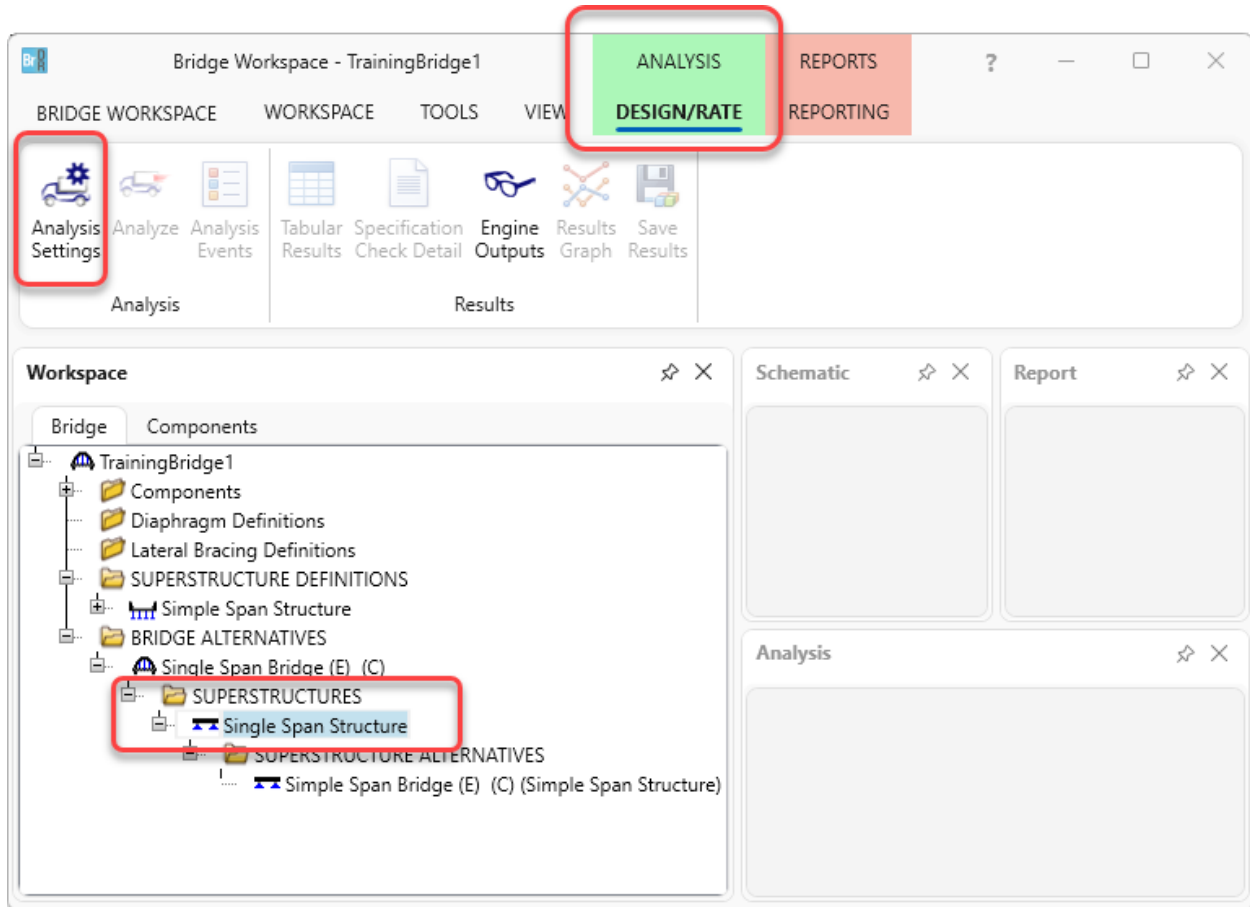

DF3 - Distribution Factor Analysis (NSG - LRFR)

Select **Dist Factor-Line Girder** as the Analysis Type and **LRFR** as the Rating Method. This will cause the distribution factor analysis to be performed and LRFR analysis will be performed during the traditional line girder analysis. Then select the **NSG Truck** as the permit vehicle to use. Note that a standard gage vehicle can also be used in the analysis. A vehicle can be added in the Adjacent lane vehicle as well. However, in this example, no vehicle will be added for the adjacent lane.

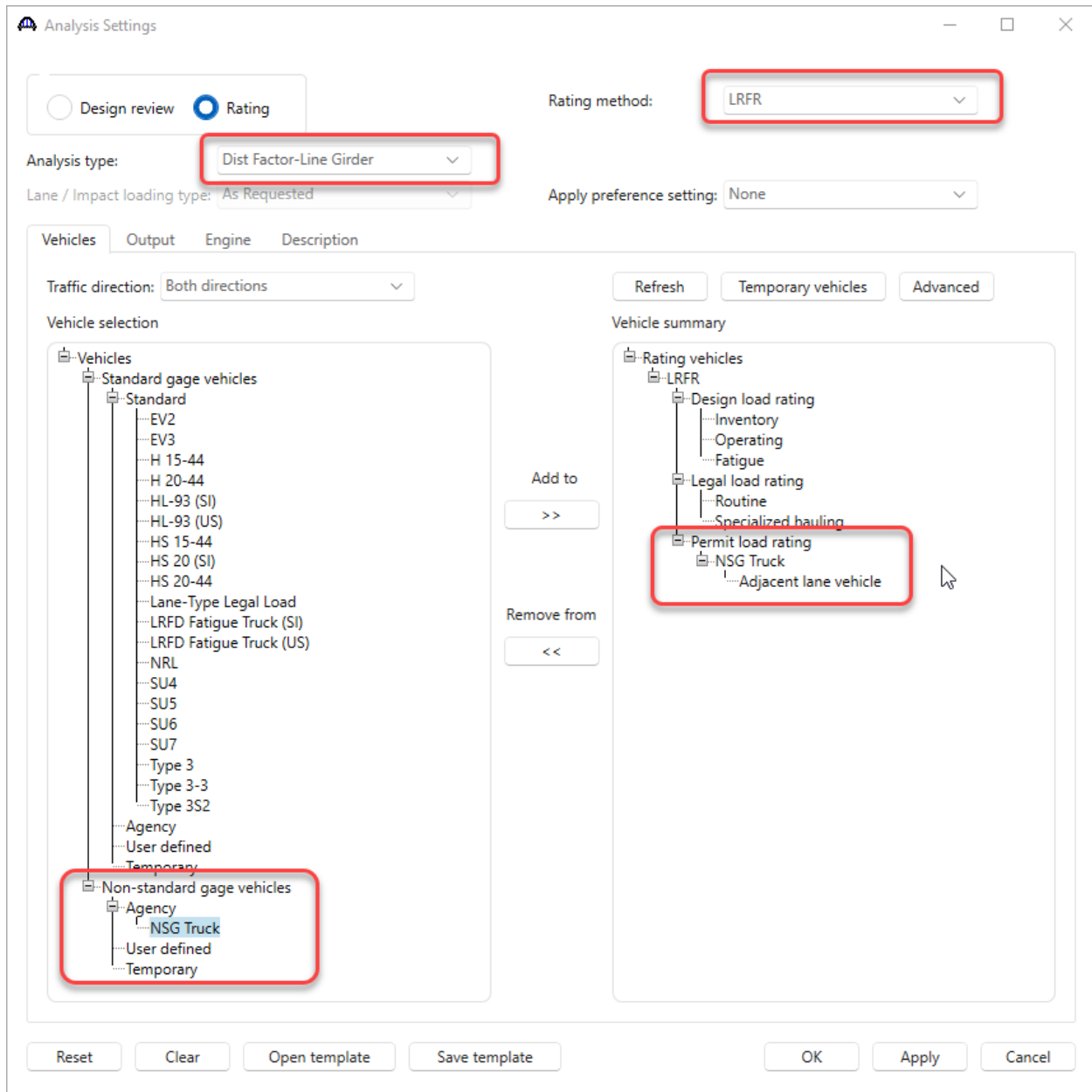

Click **OK** to save the settings and close the window.

DF3 - Distribution Factor Analysis (NSG - LRFR)

Click the **Analyze** button in the Analysis Group to initiate the Distribution Factor-Line Girder analysis.

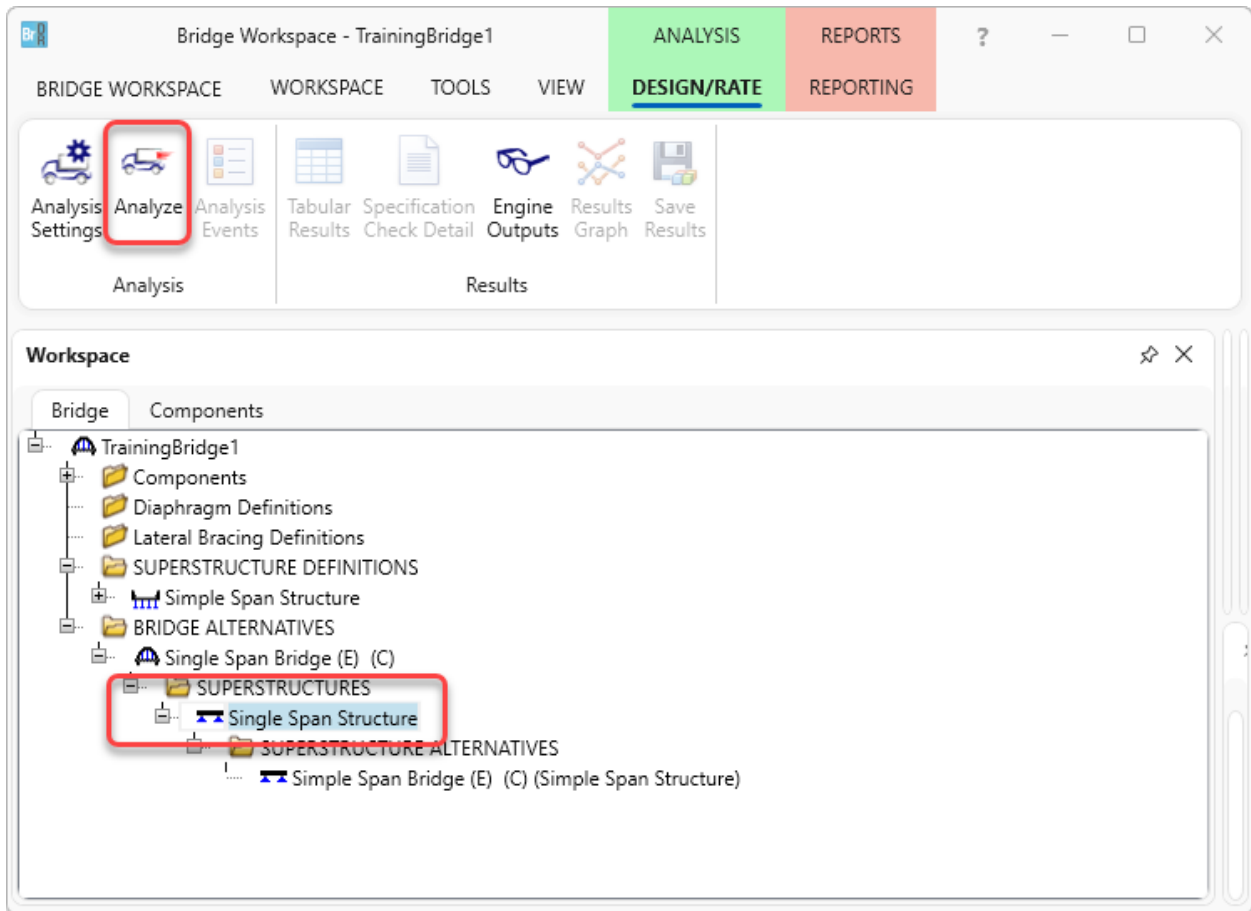

The **Analysis Progress** window will show the progress of the 3D and 2D finite element analyses. The AASHTO program is then run for the traditional girder line analysis using the distribution factors computed by the distribution factor analysis.

DF3 - Distribution Factor Analysis (NSG - LRFR)

The output of the distribution factor analysis can be found by selecting **Engine Outputs** from the **Results** group of the **DESIGN/RATE** ribbon when the superstructure is selected in the **Bridge Workspace** tree.

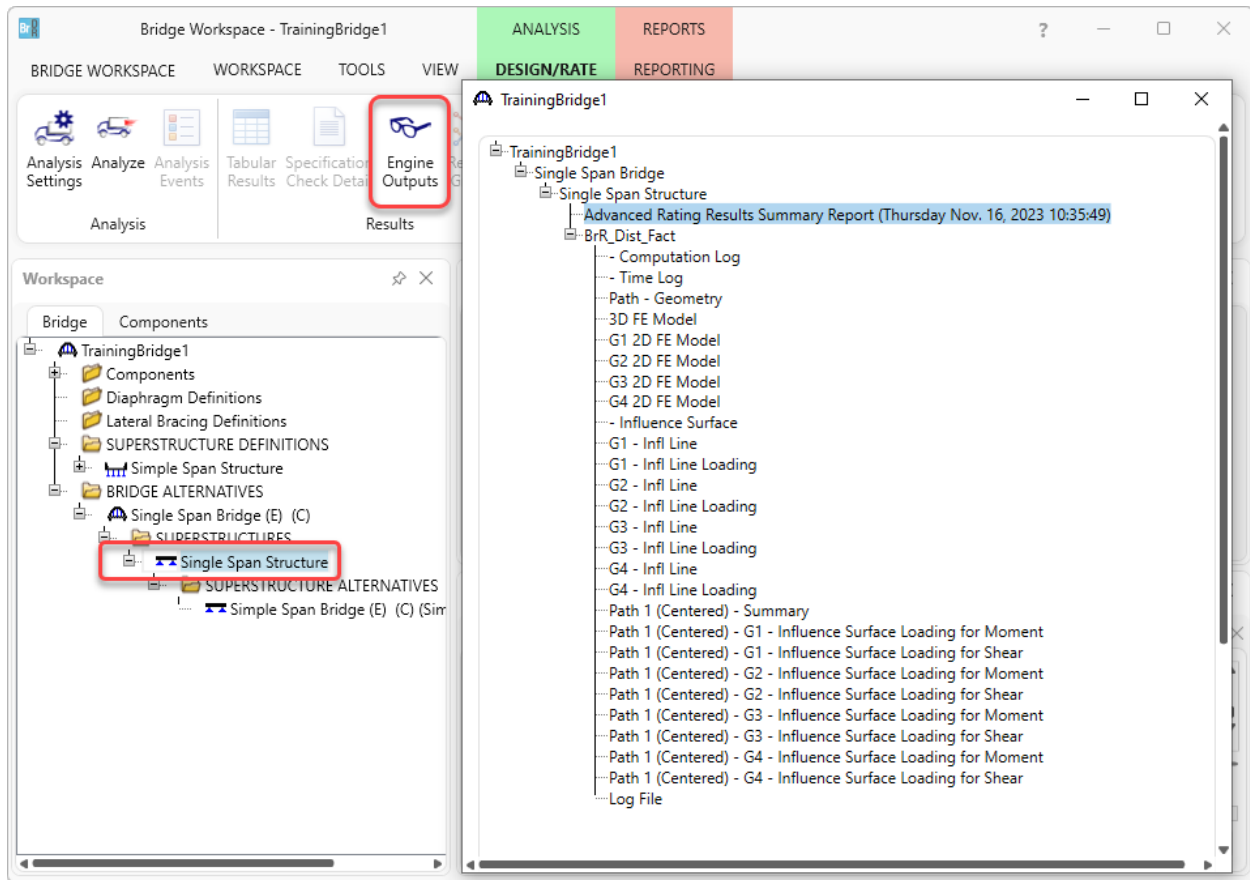

The output of the distribution factor analysis includes the 3D and 2D finite element models, the influence surface and influence lines and their loading.

DF3 - Distribution Factor Analysis (NSG - LRFR)

Double-click the **Advanced Rating Results Summary Report** for a summarized report of the rating. The critical distribution factors used for each girder are also listed in the report.

Bridge Name: Training Bridge 1(LRFD)

Bridge ID: 1

Super Structure: Single Span Structure

Analysis Date: Thursday, November 16, 2023 10:35:35

Permit Vehicle: NSG Truck

Adjacent Permit Vehicle:

Loading Path: NSG (Centered) - ADJ (None)

Member	Permit Capacity (Ton)	Permit Location / Element Name (ft)	Permit Rating Factor	Permit Limit State	Success / Failure
G1	246.32	80.500 (1 - 50.00%)	5.598	STRENGTH-II Steel Flexure Stress	Success
G2	95.23	80.500 (1 - 50.00%)	2.164	STRENGTH-II Steel Flexure Stress	Success
G3	95.40	80.500 (1 - 50.00%)	2.168	STRENGTH-II Steel Flexure Stress	Success
G4	246.08	80.500 (1 - 50.00%)	5.593	STRENGTH-II Steel Flexure Stress	Success

Member	Start Range (ft)	End Range (ft)	Moment Dist. Factor (Lanes)	Shear Dist. Factor (Lanes)
G1	0.000	161.000	0.171	0.132
G2	0.000	161.000	0.324	0.512
G3	0.000	161.000	0.323	0.508
G4	0.000	161.000	0.171	0.133

DF3 - Distribution Factor Analysis (NSG - LRFR)

The results of the **AASHTO LFR** Engine line girder analysis of each girder can be viewed by selecting the **member alternative** in the **Bridge Workspace** tree (as shown below) and clicking the **Engine Outputs** button in the **Results** Group.

